



**eCATALOG**solutions

# Toshiba Improves Digital Experience for Customers with Online Product Catalog

A Case Study

# TOSHIBA

# Toshiba Unlocks Hidden Revenue From Their Digital Product Catalog with 3D CAD Models

Toshiba International Corporation launched a new interface of their digital 2D and 3D CAD model library on their website in 2014. Later that year, they announced a 360% quarterly increase of downloaded CAD models from their digital parts catalog.

By championing digital customer experience and helping their customers find what they need to do their jobs quickly, easily and accurately, Toshiba unlocked the true potential of their digital product catalog.

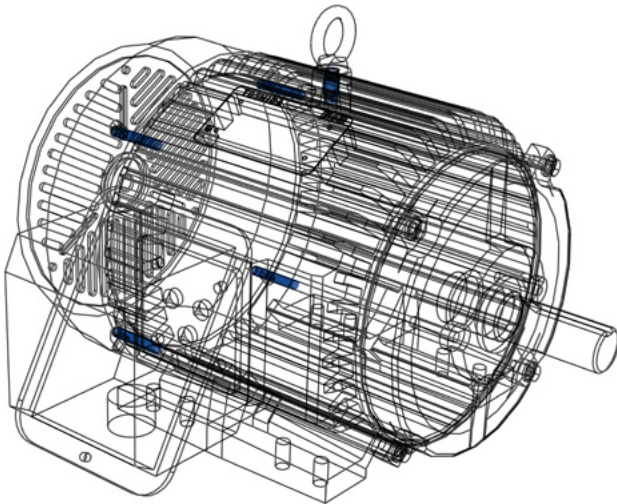

The new electronic parts catalog retains the same high-quality content Toshiba had previously offered with its CADENAS eCATALOG solutions configurator with an improved design focusing on a better user experience. The new embedded design also helps TIC better retain and convert visitors to its site.

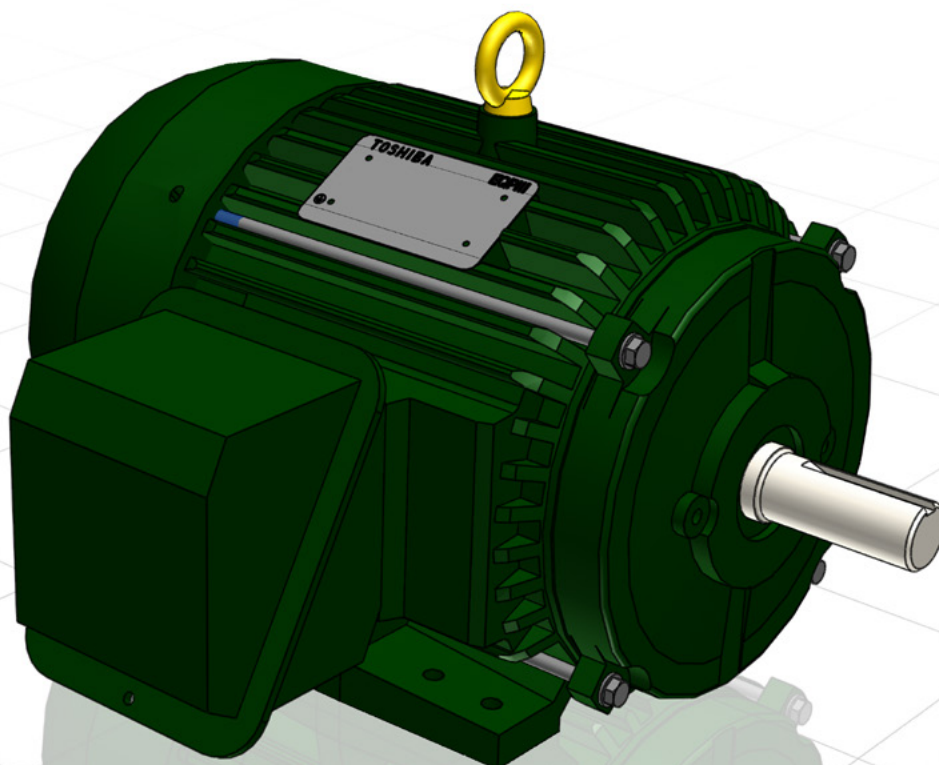





## Toshiba's Online CAD Catalog Powers 360% Increase of CAD Downloads

After launching the improved configurator in the first quarter, the download rate of digital parts increased to 191,000, a 360% gain from 41,000 the previous quarter prior to the upgrade.

### Creating a More Streamlined Customer Experience

To make their product models more accessible to online engineers, Toshiba launched a new, embedded interface to their 2D and 3D CAD model library. This made it easier and faster for engineers to find and download product models for their applications, shortening design time and improving product accuracy.



"When we originally set out to implement our online product configurator, we were looking to set the pace for the motor industry by making high-quality downloadable files more accessible to our customers. We're always looking for ways to improve the experience for our customers. We knew there were benefits of embedding our configurator seamlessly on our site, rather than through a pop-up," says John Rama, Business Director, Low Voltage Motors & Drives.

---

»» We never expected such a significant increase of more than 300%, which shows we delivered what our customers wanted and exceeded our own expectations as well. ««



John Rama  
Business Director, Low Voltage Motors & Drives  
Toshiba International Corporation

---

**TOSHIBA**



## More Flexibility and Access to Native CAD Model Downloads

A leader in the design and manufacture of motors, adjustable speed drives, controls and other power electronic products, Toshiba originally launched its online product configurator in 2009. They chose CADENAS PARTSolutions because of the flexible implementation and vast selection of file formats available for customers to download.

CADENAS PARTSolutions has one of the widest selections in the industry with native outputs to all major CAD systems. This gave Toshiba the power to provide more than 150 CAD and imaging formats as instant, native downloads to their customers, as well as 3D product data sheets and configurable 3D interactive previews of the exact Toshiba product.

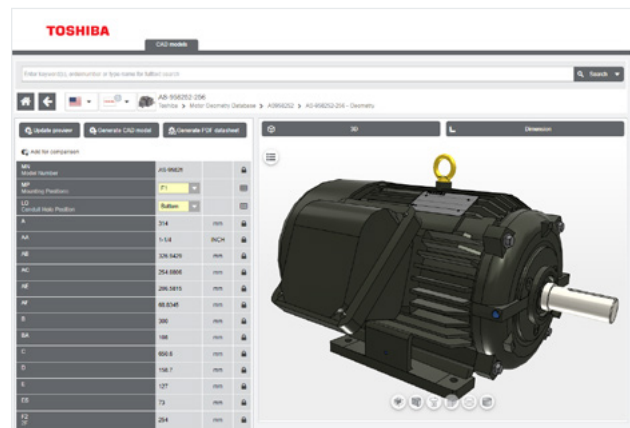

»» Toshiba truly embraced the concept of digital customer experience. What seemed to be small upgrades and modifications yielded massive results for Toshiba when they helped customers navigate, download, and find what they need to do their job. ««



Douglas Korneffel  
Chief Technology Officer  
CADENAS PARTSolutions LLC

# Same Quality Products – Continued Growth

Toshiba is continually expanding and improving their digital parts catalog, adding more specialized products, making it easier for more engineers to configure, download, and purchase the components they need.

Parameter	Value	Unit	Lock
MN Model Number	M3A44600S		🔒
HP Horse Power	6000.000		🔒
CR Current Rating	744	amps	🔒
FRAME Frame	4		🔒
CO Cooling	Standard		🔒
BYP Bypass	No Bypass		🔒
IV Input Voltage	4160V		🔒
HV HV Input Cubicle	N/A		🔒
IS Isolation Switch	STD Switch		🔒
CP Control Panel	STD Panel		🔒
MLL Motor Lead Length	0 to 2000 ft		🔒
FILTER Filter	Standard Output		🔒

»» Originally, we made our most popular products available for digital download, and received a lot of traction. As time went on, we received many requests for more specialized products to be available in the same way.

Engineers of large OEM products and industrial projects want the same convenience as other designers. They need that same quick turn-around you can only get with an on-demand digital catalog. ««



John Rama  
Business Director, Low Voltage Motors & Drives  
Toshiba International Corporation

**TOSHIBA**

## Company Info

# TOSHIBA

[www.toshiba.com/tic](http://www.toshiba.com/tic)



[www.cadenas.de/en](http://www.cadenas.de/en)

### Toshiba International Corporation

TIC is a Toshiba America Inc. (TAI) Group Company, a wholly owned subsidiary of Toshiba Corporation. TIC is headquartered in Houston, Texas and employs approximately 2,000 people. TIC provides application solutions to a wide range of industries including industrial, power systems, and transmission and distribution systems. For more information about TIC, please visit them online.

### CADENAS

CADENAS is a leading software manufacturer in the areas Strategic Parts Management and parts reduction (PARTsolutions) as well as Electronic CAD Product Catalogs (eCATALOGsolutions). With its customized software solutions, the company acts as a link between component manufacturers with their products and the buyers.

With its 380 employees in 19 locations worldwide, the name CADENAS (Spanish for "chains") has stood for success, creativity, support, and process optimization since 1992.

#### The CADENAS Group worldwide:

Augsburg Phone: +49 821 2 58 58 0 - 0  
Wolfsburg Phone: +49 5362 94 88 20  
Esslingen Phone: +49 711 900 37 730  
Essen Phone: +49 201 2 48 89 9 - 0

Austria Phone: +43 664 24 52 713  
Italy Phone: +39 051 04 16 776  
France Phone: +33 4 74 55 26 96  
Sweden Phone: +46 723 038 090

USA Phone: +1 513 453-04 53  
UK Phone: +44 7949 69 67 51  
Croatia Phone: +385 35 63 82 25  
South Korea Phone: +82 505 936 - 93 60

Turkey Phone: +90 212 272 10 55  
Japan Phone: +81-3-59 61-50 31  
China Phone: +86 21 63 55 13 18

Copyright 1992-2019 CADENAS GmbH. All rights reserved. CADENAS, PARTsolutions, eCATALOGsolutions, PARTcommunity, PURCHINEERING, PARTcloud, ePRODUCTplacement, PARTserver, smartPART, web2cad und BIMcatalogs are brands of CADENAS GmbH, Augsburg. All further brand names, company names or product names are brands or registered trademarks of their rightful owner. Not liable for any information.

Status: December 2019 | GB | designed by [www.canvas.de](http://www.canvas.de)